



GUIDELINES

COPRAR Container Loading Instruction

(D95B version 1.2)

Department : PSA Antwerp EDI Support team

PSA Antwerp Guidelines COPRAR load.

INTRODUCTION

This document is composed merely to facilitate the development of new EDI COPRAR links with our customers and to guide and assist them through the programming and test phase. This should reduce the research and development on the customer side significantly.

As PSA Antwerp is an active participant of the world wide SMDG EDI discussion forum since its foundation, this document is partially based on the SMDG COPRAR user manual (Version 1.2), enriched with some useful tips. It is not our intention to replace the official SMDG manual. These guidelines should be used in addition to the COPRAR manual.

Suggestions and/or feedback are always welcome, as this document is also based on experiences, gained from past COPRAR projects. Each time some new features are added, we provide our customers with an update.

Best regards,

The PSA Antwerp EDI Support team

COPRAR load order

The Container Loading Instructions Message (Coprar)

The COPRAR message is sent by the shipping agent to the container terminal operator. It contains a list of all the full and empty containers to be loaded on board of a specific vessel

The accuracy of the container information in this message is of innumerable importance. In order to send an up to date COPRAR loading message, the loading information can be linked to the container information provided by our electronical daily move messages (CODECO). See APPENDIX B for more information regarding this matter.

SEGMENT TABLE

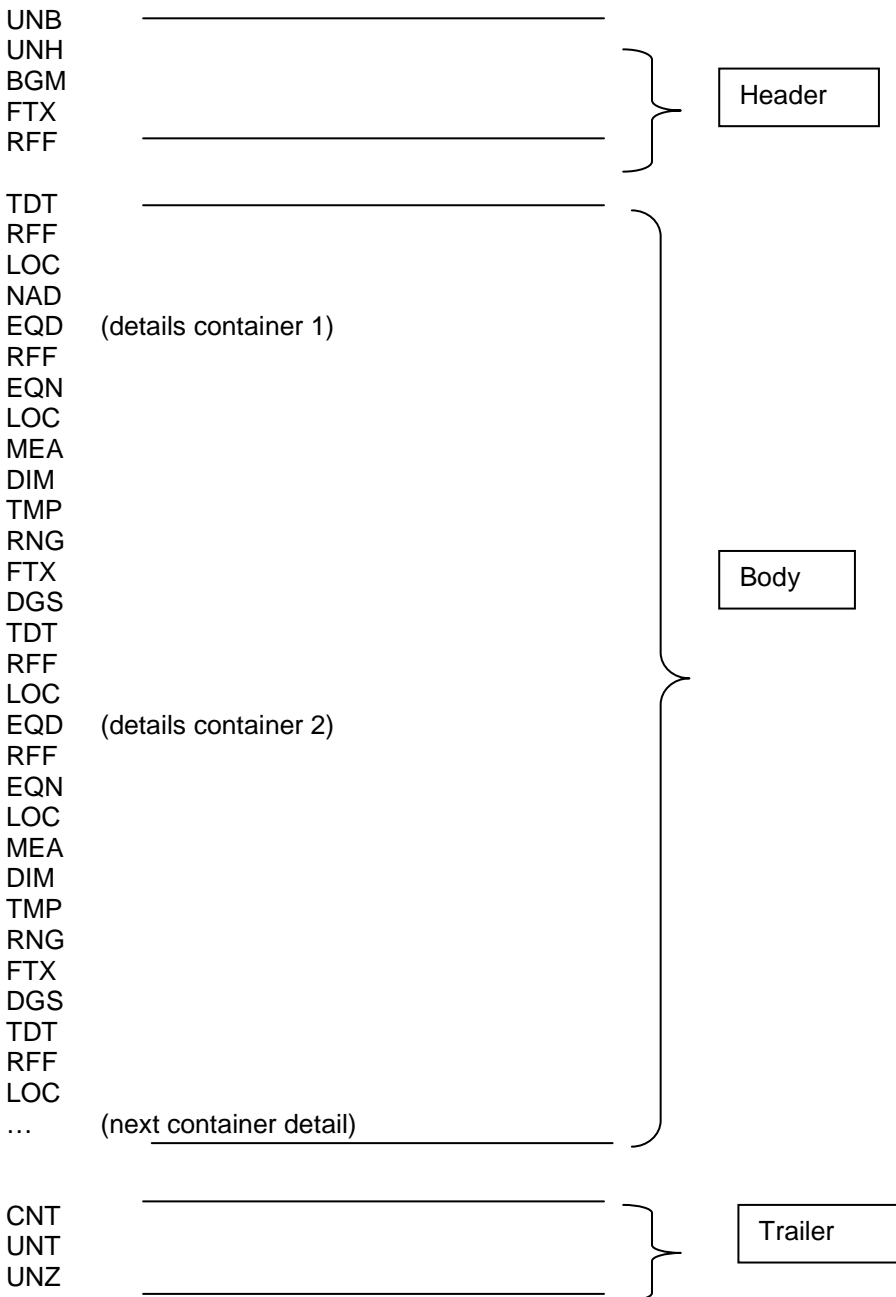

SEGMENT TABLE: table of contents

Tag Name

Header

UNH Message header
BGM Beginning of message
FTX Free Text
RFF Reference

Segment group 1

TDI Details of transport
RFF Reference
LOC Place/location identification

Segment group 2

NAD Name and address

Segment group 3

EQD Equipment details
RFF Reference
EQN Number of units
LOC Place/location identification
MEA Measurements
DIM Dimensions
TMP Temperature
RNG Range details
FTX Free text
DGS Dangerous goods

Segment group 4

TDI Details of transport
RFF Reference
LOC Place/location identification

Trailer

CNT Control total
UNT Message trailer

Interchange header – UNB-Segment

Structure:

UNB

+

0001 = Syntax identifier with as value “UNOA” (indicates the use of level ‘A’ character set. => see *APPENDIX D for more information*).

:

0002 = Syntax version number with as value “2”.

+

0004 = Sender identification: mailbox number of the message sender.

+

0010 = Recipient identification: mailbox number of the message recipient.

+

0017 = Date of preparation (YYMMDD).

:

0019 = Time of preparation (HHMM).

+

0020 = Interchange control reference with a unique number which is also specified in the UNZ segment.

,

Example:

UNB+UNOA:2+<SENDER>+101311+000508:1106+000005

Message version – UNH-Segment

For mapping reasons, also enter the Association Assigned Code (0057) in the UNH-segment.

Structure:

UNH

+

0062 = *Message reference number* with as value a unique sequence number per message.

+

0065 = *Message type identifier* with as value "COPRAR".

:

0052 = *Message type version number* with as value "D".

:

0054 = *Message type release number* with as value "95B".

:

0051 = *Controlling agency* with as value "UN".

:

0057 = *Association assigned code* with as value the used manual version number (= "ITG12").

'

Example:

UNH+0002132+COPRAR:D:95B:UN:ITG12'

Instruction type – BGM-Segment

For a loading instruction, the value of data element 1001 is “45”

Structure:

BGM

+

1001 = *Instruction type* with as value “45” (=transport loading instruction).

+

1004 = *Document/message number*.

+

1225 = *Message function, coded* with as value “9” (= original message).

,

Example for loading instruction:

BGM+45+20000002132+9'

Message function – BGM-Segment

In the BGM segment, the code value of data element 1225 (message function, coded) indicates the function of the message.

9 = ORIGINAL (CREATE): First transmission of the message.

To send the original instruction, the message function in BGM (1225) is “9”. The reference qualifier in the RFF segment (1153) has to be “XXX”, followed by the reference number (1154) with value “1” (= dummy value). For structure: see “Reference” below.

Example for creation of loading instruction:

```
UNB+UNOA:2+101600+101311+000504:1040+34'  
UNH+0002132+COPRAR:D:95B:UN:ITG12'  
BGM+45+20000002132+9'  
FTX+OSI++L'  
RFF+XXX:1'  
TDT+20+A0035+1++CAST+++ZCEB7:103::CAST PERFORMANCE'  
RFF+VON:A0027'  
LOC+9+BEANR:139:6+BEANR869:TER:ZZZ'  
DTM+133:20004230:203'  
NAD+CF+NOA'  
...
```

Other service information – FTX-Segment

The text subject qualifier (4451) with value “OSI”, is followed by data element 4441 (free text, coded) with value:

‘L’ for Loading.

Structure:

FTX

+

4451 = *Text subject qualifier* with as value “OSI” (=other service information).

++

4441 = *Text reference (free text, coded)* with as value “L”.

‘

Example:

FTX+OSI++L’

Reference – RFF-Segment

Structure:

RFF

+

1153 = *Reference qualifier* with as value “XXX” (= dummy value for original message).

:

1154 = *Reference number* with as value “1” (=dummy value).

,

Example:

See “Message function” above.

1. SEGMENT GROUP 1

A group of segments to indicate information regarding the main carriage.
This segment group identifies the main carriage or vessel details for all items of equipment in the message.

1.1. Vessel details – Group 1 – TDT Segment

This segment specifies the transport details such as mode of transport, radio call sign,...
The TDT segment must be sent.

Structure:

TDT
+
8051 = *Transport stage qualifier* with as value "20" (=main carriage).
+
8028 = *Conveyance reference number* with as value the carrier's main voyage number.
+
8067 = *Mode of transport, coded* with as value "1" (= maritime transport).
++
3127 = *Carrier identification* with as value the code of the vessel operator.
:
1131 = *Code list qualifier* with as value "172" (= carrier code).
:
3055 = *Code list responsible agency, coded* with as value "20" (=BIC).
+++
8213 = *Id of means transport* with as value the international radio call sign (recommended).
:
1131 = *Code list qualifier* with as value "103" (= radio call sign).
::
8212 = *Id of the means of transport* with as value the full name of the vessel (= optional).
,

Example:

TDT+20+0398+1+++MSC:172:20+++3FWO5:103::MSC INSA' (also see below)

1.2. Vessel voyage number – Group 1 – RFF-Segment

This segment is always used to specify the main voyage number, or, if you are acting as co-loader, the alternative voyage number. So also when you are not acting as co-loader, the main voyage number which is also specified in the TDT-segment (above), has to be repeated in this segment.

Structure:

RFF

+

1153 = *Reference qualifier* with as value the code "VON" (= voyage number).

:

1154 = *Reference number* with as value the main voyage number or the alternative voyage number.

,

Example:

For vessel MSC INSA:

- The MSC carrier's main voyage number is "0398".
- For carrier operator "MSC" (Mediterranean Shipping Company), the alternative voyage number for the MSC INSA is "001025".
- For co-loader "LTP" (Lloyd Triestino), the alternative voyage number for the MSC INSA is "0248S".
- For co-loader "ACL" (Atlantic Container Lines), the alternative voyage number for the MSC INSA is "0668".

TDT and RFF segment in COPRAR:

```
TDT+20+0398+1++MSC:172:20+++3FWO5:103::MSC INSA'  
RFF+VON:001025'  
LOC+9+BEANR:139:6+BEANR869:TER:ZZZ'  
NAD+CF+MSC
```

TDT and RFF segment in COPRAR :

```
TDT+20+0398+1++MSC:172:20+++3FWO5:103::MSC INSA'  
RFF+VON:0248S'  
LOC+9+BEANR:139:6+BEANR869:TER:ZZZ'  
NAD+CF+LTP
```

TDT and RFF segment in COPRAR :

```
TDT+20+0398+1++MSC:172:20+++3FWO5:103::MSC INSA'  
RFF+VON:0668'  
LOC+9+BEANR:139:6+BEANR869:TER:ZZZ'  
NAD+CF+ACL
```

This means that we will receive three separate electronic loading order messages:

- one from the shipping agent representing MSC
- one from the shipping agent representing LTP
- one from the shipping agent representing ACL

When we are to report the loading operation for vessel MSC INSA electronically, we will in return use the same alternative voyage numbers to report to the parties concerned. In this example, these parties are the shipping agents, representing MSC, LTP and ACL.

1.3. Port of loading – Group 1 – LOC-segment

This segment is used to specify the operational port of loading;
The LOC at this level identifies locations associated with the main carriage.

The Related Location One Identification (3223) can have one of the following values:

- “BEANR869” for quay 869 (Europaterminal)
- “BEANR420” for quay 420 (Churchilldok)
- “BEANR913” for quay 913 (Noordzeeterminal)
- “BEZEE206” for Zeebrugge quay 206 (Container Handling Zeebrugge)
- “BEANR1742” for quay 1742 (Deurganckdok)
- “BEANR336” for quay 336 (NHS)

(See <http://www.smdg.org/> → documents → code list → SMDG Terminal Facilities codes list.)

Structure:

LOC

+

3227 = *Place/location qualifier* with as value “9” (= operational port of loading) → in case of loading.

+

3225 = *Place/location identification* with as value the UN-Locode of port of departure (“BEANR” for Antwerp or “BEZEE” for Zeebrugge).

:

1131 = *Code list qualifier* with as value the code “139” (=port).

:

3055 = *Code list responsible agency, coded* with as value the code “6” (= UN).

+

3223 = *Related place/location one identification* with as value the terminal/berth of departure (for codes: see above).

:

1131 = *Code list qualifier* with as value the code “TER” (= terminal).

:

3055 = *Code list responsible agency, coded* with as value “ZZZ” (= mutually agreed).

,

Example:

LOC+9+BEANR:139:6+BEANR869:TER:ZZZ'

2. SEGMENT GROUP 2

A group of segments to identify a party and/or addresses and related contacts.
This segment group is mandatory in the message and must always be used.

2.1. Shipping line service – Group 2 – NAD-Segment

This segment specifies the name/address and their related function. As Party Qualifier (3035), value "CF" (Container operator) has to be used.
The NAD segment at this level must always be sent.

Structure:

NAD

+

3035 = *Party qualifier* with as value "CF" (=container operator).

+

3039 = *Party id identification* with as value the name of the line agency.

,

Example:

NAD+CF+HYU'

3. SEGMENT GROUP 3

A group of segments to specify containers equipment details.
This segment group must always be sent in the COPRAR message.

3.1. Equipment details – Group 3 – EQD-Segment

To identify a unit of equipment.
The EQD segment must always be sent.

Structures:

EQD

+

8053 = *Equipment qualifier* with as value "CN" (=container).

+

8260 = *Equipment identification number* with as value the container number.

+

8155 = *Equipment size and type identification* with as value the ISO code for the corresponding container.

:

1131 = *Code list qualifier* with as value "102" (=size and type).

:

3055 = *Code list responsible agency, coded* with as value "5" (= ISO).

++

8249 = *Equipment status, coded* with as value "2" (= export) OR "6" (=in case of transshipment).

+

8169 = *Full/empty indicator, coded* with as value "4" (= empty) or "5" (= full).

'

Example

For a loading instruction, export containers:

(For Full): EQD+CN+TRLU1234567+4210:102:5++2+5'

(For Empty): EQD+CN+TRLU1234567+4210:102:5++2+4'

(For Empty): EQD+CN++4210:102:5++2+4'

Note !!

There are two possible ways to identify an empty unit.

1/ With container number -> EQD+CN+**TRLU1234567**+4210:102:5++2+4'

2/ Without container number, only ISO code -> EQD+CN++**4210**:102:5++2+4'

Dummy Containers (for Full Containers):

If the container unit number isn't known at the time the loading order is sent, a dummy container number has to be used.

The syntax of such a dummy number can be composed as follows:

“***”+ voyage number + sequence number, limited to max. 12 characters.

Example:

**77W000001

The use of these dummy container numbers can be significantly decreased by reporting the terminal container moves (with CODECO message) more often. See also APPENDIX B.

Unknown ISO code:

In case the ISO code is not known for a specific container, the following codes may be used (as in EDI MOVINS message version 2.0.4 EQD group 4):

“4***” = Length = 40 FT, rest unknown
“2***” = Length = 20 FT, rest unknown
“42***” = 40 Ft 8’6”, rest unknown
“22***” = 20 Ft 8’6”, rest unknown
“40***” = 40 Ft 8’0”, rest unknown
“20***” = 20 Ft 8’0”, rest unknown

For type indications, see the next examples (the length is always mandatory) :

“2*0*” = 20 Ft dry box, rest unknown
“4*2*” = 40 Ft reefer, rest unknown

Example:

EQD+CN+TRLU1234567+4***:102:5++2+5' (in case only the container length is known: 40 FT)

Containers On Hold:

If the container unit has to be “on hold” (not to be loaded until further notice from the agency), add a “.” behind the container number.

This specific container will go into error and can not be loaded until the adjustment is made by the PSA chief-tallyman (deletion of “.”).

This rule does not apply when working with dummy containers.

Example:

EQD+CN+TRLU1234567.+4210:102:5++2+5'

3.2. Booking reference number – Group 3 – RFF-Segment

In this segment, the corresponding booking reference can be specified.

Structure:

RFF

+

1153 = *Reference qualifier* with as value "BN" (=Transport equipment announcement number).

:

1154 = *Reference number* with as value the corresponding booking reference.

'

Example:

RFF+BN:ANTA000001'

3.3. B/L reference number – Group 3 – RFF-Segment

In this segment, the corresponding bill of lading reference can be specified.

Structure:

RFF

+

1153 = *Reference qualifier* with as value "BM" (=B/L number).

:

1154 = *Reference number* with as value the corresponding bill of lading reference.

,

Example:

RFF+BM: AALUCT47781'

3.4. Equipment sequence number – Group 3 – RFF-Segment

This is very interesting information because it eases the co-ordination between the PSA Antwerp operational department and the communication partner. An equipment sequence number can be used as quick reference. This sequence number is a unique number for each equipment detail and can be specified in the RFF-segment with Reference Qualifier (1153) "AAY" (= Carrier's agent reference). Because this sequence number is to be used for co-ordination means, the sequence numbers in de COPRAR EDI file have to be the same as the ones that the shipping agent uses.

This segment is mandatory

Structure:

RFF

+

1153 = *Reference qualifier* with as value "AAY" (= Carrier's agent reference).

:

1154 = *Reference number* with as value a unique sequence number for each EQD.

'

Example:

...

EQD+CN+ TRLU4001466+4310:102:5++2+5'

RFF+BN:AOYM244PI003'

====>RFF+AAY:1' for the first equipment detail

LOC+11+GRPIR'

LOC+7+GRPIR'

MEA+AAE+G+KGM:32730'

EQD+CN+ZCSU4001469+4351:102:5++2+5'

RFF+BN:AOYM244PI003'

====>RFF+AAY:2' for the second equipment detail

LOC+11+GRPIR'

LOC+7+GRPIR'

MEA+AAE+G+KGM:32685'

...

3.5. N.O.S. under a segregation group – Group 3 – RFF-Segment

In order to avoid possible mistakes during loading operations, we kindly request you to fill in, besides the compulsory listing in the transport document, the possible allocation of a N.O.S. entry under a segregation group in the field 'awkward cargo' in the EDI loading order.

Structure:

RFF

+

1153 = *Reference qualifier* with as value "AKW" (= awkward cargo).

:

1154 = *Awkward Cargo code*..

'

Example:

...

EQD+CN+ TRLU4001466+4310:102:5++2+5'

RFF+BN:AOYM244PI003'

RFF+AAY:1'

RFF+AKW:SG03'

EQN+1'

LOC+11+GRPIR'

LOC+7+GRPIR'

MEA+AAE+G+KGM:32730'

...

1 acids	SG01
2 ammonium compounds	SG02
3 bromates	SG03
4 chlorates	SG04
5 chlorites	SG05
6 cyanides	SG06
heavy metals and their salts (including their organometallic	
7 compounds)	SG07
8 hypochlorites	SG08
9 lead and its compounds	SG09
10 liquid halogenated hydrocarbons	SG10
11 mercury and mercury compounds	SG11
12 nitrites and their mixtures	SG12
13 perchlorates	SG13
14 permanganates	SG14
15 powdered metals	SG15
16 peroxides	SG16
17 azides	SG17
18 alkalis	SG18

3.6. Container operator reference number – Group 3 – RFF-Segment

To be used for the container operator reference number according to the dangerous goods reference number in the stowage instructions.

One container operator reference in the EDI loading order (COPRAR EDI message) is enough in order for our operational department to be able to pinpoint the concerned IMDG container in the prestow instruction (hardcopy or movins edi file). But we suggest sending us the range of the container operator references (see example)

Structure:

RFF

+

1153 = *Reference qualifier* with as value "CV".

:

1154 = Range container operator reference numbers with "-" separator (see example).

'

Example:

...

EQD+CN+XXXU9906114+45G1:102:5++2+5'

RFF+BN:0001199'

RFF+CV:PN039 - PN046'

LOC+11+KRPUS'

LOC+PDS+KRPUS'

LOC+7+KRPUS'

MEA+AAE+G+KGM:26100'

DGS+IMD+3+1263+34.0:CEL++3-05'

DGS+IMD+3+1993+45.0:CEL++3-07*'

DGS+IMD+3+2478+-4.0:CEL++3-04'

DGS+IMD+3+1993+50.0:CEL++3-07*'

DGS+IMD+3+1263+17.0:CEL++3-05'

DGS+IMD+3+1263+56.0:CEL++3-05'

DGS+IMD+9+3077'

...

3.7. Number of units – Group 3 – EQN-Segment

The EQN-segment is used to specify the number of equipment conforming to the description provided in the preceding EQD.

Structure:

EQN

+

6350 = Number of units. → always 1 (we encourage the use of sequence numbers, so in that case the EQN number should always be).

Example:

...

EQD+CN+MNGB497401:ZZZ+4310:102:5++2+4'

RFF+BN:805224974AS4N'

RFF+AAY:01001'

EQN+1'

...

3.8. Location – Group 3 – LOC-Segment

The LOC-segment at this level is used to report locations, which relate to the movement of the container.

Locations associated with the main carriage are:

3.8.1.Operational Port of discharge: (LOC+11)

The operational port of discharge is the port of destination from the vessel point of view. In that port, the goods may be transhipped to another vessel and continue their voyage to their final port of destination (= LOC+7: see below).

! Containers must be sorted by SPOD

Structure:

LOC

+

3227 = *Place/location qualifier* with as value "11" (=operational port of discharge).

+

3225 = *Place/location identification* with as value the UN Locode of the port of discharge.

:

1131 = *Code list qualifier* with as value "139" (=port).

:

3055 = *Code list responsible agency, coded* with as value "6" (= UN).

,

Example:

LOC+11+SGSIN:139:6'

3.8.2. Place of Delivery (final destination): (LOC+7)

The place of delivery is the final port of destination from the goods point of view. From there, they will be transported to an inland destination by truck, train or barge...

But if the final port of destination is already an inland destination, then the LOC+7 = LOC+11

A container terminal like PSA Antwerp does not organise overseas inland transports (we are on the other side of the ocean...) and therefore overseas inland transport is not the scope for the responsibility of a terminal operator.

Our IT systems are not destined and not designed for it... therefore this info generates errors in our EDI systems...

So this inland transport info needs to be visible only to overseas inland transport operators or forwarders / shipping customers only.

Container terminals always have a port scope of two ahead, so worst case for PSA Antwerp is something like:

SG SIN (Port of Singapore) / JP UKB (Port of Kobe, Japan).

Origin: we always inform the next coming container terminal (via BAPLIE EDI message) in this case of the port of Singapore.

We tell them that the container will be transhipped to Kobe so that they stack it in their yard properly...

In the port of Kobe our scope ends for PSA Antwerp.

If the port of Kobe a second transshipment occurs to for example Sydney, Australia, then Sydney is not the scope of PSA Antwerp anymore, it does belong to the scope of container terminal PSA in Singapore, two ports ahead so PSA has a scope port of Kobe and the port of Sydney...

All SMDG container EDI messages that we use together are designed in that way... a terminal scope of maximum two ports ahead...

Structure:

LOC

+

3227 = *Place/location qualifier* with as value "7" (=place of delivery, final destination).

+

3225 = *Place/location identification* with as value the UN Locode of the port of final destination or stowage purposes.

:

1131 = *Code list qualifier* with as value "139" (=port).

:

3055 = *Code list responsible agency, coded* with as value "6" (= UN).

,

Example:

LOC+7+AEDXB:139:6'

3.9. Container Gross Weight – Group 3 – MEA-Segment

In this segment, the gross weight of the corresponding container is specified

Structure:

MEA

+

6311 = *Measurement Application Qualifier* with as value “AAE” (=measurement).

+

6313 = *Measurement dimensions*, coded with as value “G” (= gross weight = weight of container + content of container).

+

6411 = *Measure unit qualifier* with as value “KGM” (=kilogram).

:

6414 = *Measurement value* with as value the actual gross weight.

,

Example:

MEA+AAE+G+KGM:24000'

Correct weights are extremely important concerning the port dues (= liggelden Haven van Antwerpen).

Based on the gross tonnage from the Coprar discharge & loading, the leading operator's water clerk will declare this gross tonnage to the Port authorities. Port dues will then be calculated.

3.10. Overheight / Oversized containers – Group 3 – DIM-Segment

The Group 3 DIM-Segment is used to specify dimensions, which exceed those of the standard dimension reported in the preceding EQD-Segment. (The ISO code in the EQD segment specifies the standard size and the height of a container.) The providing of oversizes in the COPRAR message is much more accurate when we are reporting the daily moves on a frequent basis (CODECO message). So we strongly suggest to process the last minute info and feed the container oversizes info that was retrieved from the daily moves back into the matching COPRAR for the loading of the vessel. See also APPENDIX B

As Dimension Qualifier (6145), following values are possible:

- " 5 " => Off-standard dimension front (over-length)
- " 6 " => Off-standard dimension back (over-length)
- " 7 " => Off-standard dimension right (over-width)
- " 8 " => Off-standard dimension left (over-width)
- " 9 " => Over-height

Structure:

DIM

+

6145 = *Dimension qualifier* with as value "5" or "6" or "7" or "8" or "9" (see above).

+

6411 = *Measure unit qualifier* with as value "CMT" (= centimetres).

:

6168 = *Length dimension* with as value the over-length.

:

6140 = *Width dimension* with as value the over-width.

:

6008 = *Height dimension* with as value the over-height.

'

Examples:

For over-length, front: DIM+5+CMT:20'

For over-length, back: DIM+6+CMT:30'

For over-width, right: DIM+7+CMT::15'

For over-width, left: DIM+8+CMT::15'

For over-height: DIM+9+CMT:::50'

Also a combination is possible, for example a container with an over-length of 20 cms, an over-width (right and left) of 10 cms and an over-height of 30 cms:

...

DIM+5+CMT:20'

DIM+7+CMT::10'

DIM+8+CMT::10'

DIM+9+CMT:::30'

...

3.11. Fixed reefer temperature specification – Group 3 – TMP-Segment

To specify a fixed reefer temperature, the Group 3 TMP-Segment is used and is composed as follows:

The temperature setting (6246) is a 3-digit integer number. ("." excluded)

Examples:

- * "20.0" returns 020° = 20°
- * "003" returns 003° = 3°

Structure

TMP

+

6245 = *Temperature qualifier* with as value "2" (= transport temperature).

+

6246 = *Temperature setting* with as value the actual fixed temperature (see above).

:

6411 = *Measure unit qualifier* with as value the code "CEL" (=Celcius) or "FAH" (=Fahrenheit).

,

Examples:

- * TMP+2+10.0:CEL' → returns 010°C
- * TMP+2+05.0:CEL' → returns 005°C
- * TMP+2+-05.0:CEL' → returns -005°C

☞ If there is a range of temperatures given, the Group 3 RNG-segment should be used instead of the TMP-Segment.

☞ Mind that Numeric data element values shall be regarded as positive. ... So, positive temperature is specified without the "+"-sign.

+ Temperature setting should be given as described above. Certain combinations are not supported and should never be used:

- * TMP+2+00,0: CEL' → comma
- * TMP+2+00.0' → no measure unit qualifier
- * TMP+2+00.0°: CEL' → {{°}}

Etc...

→ Result: a translation error; the file **can not be processed automatically**. Resending the EDI file is needed to process the loading/discharge order.

3.12. Range of reefer temperatures – Group 3 – RNG-Segment

The Group 3 RNG-Segment is used to specify a range of temperatures, if applicable.

Structure:

RNG

+

6167 = *Range type qualifier* with as value “5” (= temperature range).

+

6411 = *Measure unit qualifier* with as value the code “CEL” (=Celcius) or “FAH” (=Fahrenheit).

:

6162 = *Range minimum* with as value the minimum temperature.

:

6152 = *Range maximum* with as value the maximum temperature.

,

Example:

RNG+5+CEL:-09.0:05.0' for a range from -9.0°C to 5 .0°C

3.13. Instructions for special services or actions – Group 3 – FTX-Segment

!! Maximum 9 FTX-segments can be used in this group (FTX+AAD under DGS not included) !!

For loading instructions:

3.13.1. Stowage instructions

This segment is used to specify the stowage instructions. As Text Subject Qualifier (4451) "HAN" has to be specified. As Free Text Coded (4441) next values can be entered:

- "OD" = on deck stowage
- "UD" = under deck stowage
- "AB" = away from boiler
- "AFH" = under deck, away from heat
- "BC" = block stowage
- "UW" = under waterline

Structure:

FTX

+

4451 = *Text subject qualifier* with as value "HAN" (=handling instruction).

++

4441 = *Handling code* with as value "OD", "UD", ... (see above).

'

Example:

FTX+HAN++OD' for on deck stowage.

3.13.2. General information

Specifying general information should be done in the FTX segment with as Text Subject Qualifier (4451) "AAI" (=general information).

!! Please note that a free text segment can't be interpreted by a computer system. Therefore we advise to put as less information as possible in this segment.

Structure:

FTX

+

4451 = *Text subject qualifier* with as value "AAI" (=general information).

+++

4440 = *Free text* with as value a description/instruction/remark (Mind the fact that this data element only may be used once per FTX-segment!!).

Example:

FTX+AAI+++HEAVY PAYLOAD'

⇒ In case you want to specify more than one general remark, you have to enter separate FTX-segments. You can't specify different remarks in 1 FTX-segment because data element 4440 may only be used once per segment.

However, always mind the fact that there only may occur 9 FTX-segments per group 3 in total (included: FTX+AAA and FTX+HAN – excluded FTX+AAD in DGS-group).

FTX+AAI+++HEAVY PAYLOAD'

FTX+AAI+++SENSITIVE TO MAGNETIC INTERFERENCE'

...

3.13.3. Goods description

Specifying goods description should be done in the FTX segment with as Text Subject Qualifier (4451) "AAA" (=goods description).

Structure:

FTX

+

4451 = *Text subject qualifier* with as value "AAA" (=goods description).

+++

4440 = *Free text* with as value a description/instruction/remark (Mind the fact that this data element only may be used once per FTX-segment!!).

Example:

FTX+AAA+++ZINC PLATE'

For more information about this FTX segment: see APPENDIX B

3.14. Multiple dangerous goods in one container – Group 3 – DGS-Segment

Maximum 9 multiple dangerous goods can be specified in the DGS-group with a DGS-segment, followed by a FTX-segment with as text subject qualifier (4451) “AAD”(= dangerous goods technical name). The FTX-segment is an outstanding DMR, which we already implemented.

The DGS-segment is composed as follows:

Structure:

DGS

+

8273 = *Dangerous goods regulations* = "IMD".

+

8351 = *Hazard code identification* = IMDG Class Number or Sub Class Number.

:

8078 = *Hazard substance/item/page number* = IMDG Code page number.

+

7124 = *UNDG Number*.

'

Example:

...

FTX+AAA+++CHEMICALS '

DGS+IMD+8:8226+1824'

FTX+AAD+++ ACETIC ACID SOLUTIONS '

DGS+IMD+8:8100+2790'

FTX+AAD+++CAUSTIC SODA SOLIDS'

DGS+IMD+8:8225+1823'

FTX+AAD+++HYDROQUINONE, SOLID OR LIQUID'

...

☞ As “FTX+AAI” is a general description of the goods in an EQD segment, the “FTX+AAD” segment is the more specific technical name per commodity.

Example :

...

EQD+CN+INBU4912891+4310:102:5++2+5'

RFF+BN:701213351'

RFF+AAY:1' => sequence number for first equipment

LOC+11+ITGIT'

LOC+7+EGALY'

MEA+AAE+G+KGM:25800'

FTX+AAI+++HEAVY PAYLOAD' (=> General information)

FTX+AAA+++ENGINE PARTS' (=> goods description)

FTX+HAN++UD'

EQD+CN+*C080E00001+4310:102:5++2+5'

RFF+BN:701213351'

RFF+AAY:2' => sequence number or second equipment

RFF+AKW:SG01' => awkward cargo

LOC+11+ITGIT'

LOC+7+JOAQJ'

MEA+AAE+G+KGM:12150'

FTX+AAI+++FLAMMABLE SOLIDS' (=> general information)

FTX+AAA+++CHEMICALS' (=> dangerous goods description)

DGS+IMD+8+2912'

FTX+AAD+++RUBBER SCRAP' (=> technical name)

...

☞ In case there are more than 9 commodities for one container (for one EQD segment), we suggest specifying the 9 most important/dangerous goods.

☞ For flax waste (IMDG class 4.1), there doesn't exist an official UN number. We suggest to use "0000" as UN number for this commodity.

4. SEGMENT GROUP 4

A group of segments to indicate details of the movement of containers by sea and by inland carriers, such as mode and means of transport and locations.

4.1. Pre- carriage information – Group 4 – TDT-Segment

If available, details concerning the transport mode of the on carriage, can be specified in this segment.

Loading instructions:

With “pre-carriage”, we mean the transport of the container from the original inland point of departure to the Hesse-Noord Natie terminal before the seagoing transport (=export).

☞ Mind the fact that in case of a loading instruction, only the pre-carriage physically occurs.

Data element 8067 (Mode of transport, coded) can have one of following codes (see structure below):

- 1 = maritime => in case of transshipment
- 2 = rail
- 3 = road
- 4 = air
- 8 = inland waterway
- 9 = mode unknown

Data element 8179 (type of means of transport identification) can have one of the following codes (see structure below)

- 11 = ship (feeder/barge)
- 13 = ocean vessel
- 25 = rail
- 31 = truck

Possible combinations of data elements 8067 & 8179:

8067	8179
1	13
2	25
3	31
8	11

Structure:

TDT

+

8051 = *Transport stage qualifier* with as value "10" (=pre-carriage transport).

+

8028 = *Conveyance reference number* with as value the carrier's main voyage number.

+

8067 = *Mode of transport, coded* with as value the corresponding code for the transport type (see code list above).

+

8179 = *Type of means of transport identification* (=optional)

+

3127 = *Carrier identification* with as value the code of the transport operator.

:

1131 = *Code list qualifier* with as value "172" (=carrier code => only in case in transshipment).

:

3055 = *Code list responsible agency, coded* with as value "20" (BIC) (=> only in case in transshipment).

+++

8213 = *Id of means transport* with as value the international radio call sign (recommended) or the Lloyd's number in case of transshipment. In case of pre carriage by truck, for example, the licence plate number can be specified).

:

1131 = *Code list qualifier* with as value "103" (= radio call sign) or "146" (Lloyd's number) (=> only in case in transshipment).

::

8212 = *Id of the means of transport* with as value the full name of the vessel (= optional) (=> only in case in transshipment).

Example:

In case of transshipment: loaded on vessel MSC INSA with call sign 3FW05 and main voyage 0398:

TDT+10+0398+1+++MSC:172:20+++3FW05:103::MSC INSA'

In case of pre-carriage by truck: Trucking company "TRANSECO" and truck licence plate number "PJE026".

TDT+10++3+31+TRSEC:::TRANSECO+++PJE026'

4.1. Reference – Group 4 – RFF-Segment (only in case of transshipment)

In this segment, the alternative voyage number of the on-carriage vessel (transshipment) can be specified.

Structure:

RFF

+

1153 = Reference qualifier with as value "VON" (=voyage number).

:

1154 = Reference number with as value the alternative voyage number.

'

Example:

RFF+VON:0045'

4.3. Place of departure – Group 4 – LOC-Segment

Structure:

LOC

+

3227 = *Place/location qualifier* with as value “5” (= place of departure).

+

3225 = *Place/location identification* with as value the UN-Locode of port of loading in case of transshipment, or the (inland) place of loading in case of pre-carriage by truck or train,...

:

1131 = *Code list qualifier* with as value the code “139” (=port).

:

3055 = *Code list responsible agency, coded* with as value the code “6” (= UN).

Example:

In case of a loading instruction:

LOC+5+USNYC:139:6' => In case of transshipment (when containers were loaded in New York).

LOC+5+BEGNE:139:6' => In case of pre-carriage by truck (when export containers were loaded at an inland facility (Gent)).

Control total – CNT-Segment

This segment is always required, also when a control total isn't required by the receiving application. If no total is required, the segment may be used with dummy values.

Structure:

CNT

+

6069 = *Control qualifier* with as value "16" (=total number of equipment).

:

6066 = *Control value* with as value the actual number of EQD –segments.

,

Example:

CNT+16:13' => In case there are 13 EQD –segments in the message

Message trailer – UNT-Segment

This segment is also mandatory. It specifies the total number of segments.

Structure:

UNT

+

0074 = *Number of segments in the message* (UNH & UNT included).

+

0062 = *Message reference number* with as value the same as in 0062 in UNH (see above).

,

Example:

UNT+29+2' =>In case there are 29 segments in the message (UNH & UNT included) and the message reference in UNH is also "2".

Full example of a COPRAR loading order for 4 containers :

UNB+UNOA:2+105000+101307+000508:1106+023497'
 UNH+046140+COPRAR:D:95B:UN:ITG12'
 BGM+45+MSC01445+9'
 FTX+OSI++L'
 RFF+XXX:1'
 TDT+20+0435+1++MSC:172:20+++P3ZD7:103::MSC INDONESIA'
 RFF+VON: 0435'
 LOC+9+BEANR:139:6+BEANR869:TER:ZZZ'
 NAD+CF+MSC:160:20'

<p>EQD+CN+INBU4912891+4310:102:5++6+5' RFF+BN:MSC13815ALY080' RFF+AAAY:1' LOC+11+USBOS' LOC+7+USBOS' MEA+AAE+G+KGM:25800' FTX+AAA+++PAPER' TDT+10+0398+1++MSC:172:20+++3FWO5:103::MSC INSA' RFF+VON:0045' LOC+5+USNYC:139:6'</p>	<p>Normal Dry Van container</p> <p>Transhipment at PSA terminal : container for loading on the MSC INDONESIA was discharged at PSA from the MSC INSA</p>
---	---

<p>EQD+CN+*C080E00001+4310:102:5++2+5' RFF+BN:MSC14366AQJ080' RFF+AAAY:2' RFF+AKW:SG01' LOC+11+USBOS' LOC+7+USBOS' MEA+AAE+G+KGM:12150' FTX+AAA+++CHEMICALS' DGS+IMD+8+2912'</p>	<p>Awkward cargo</p> <p>IMO specification</p>
--	---

<p>FTX+AAD+++RUBBER SCRAP'</p> <p>EQD+CN+YMLU4569283+4532:102:5++2+5' RFF+BN:MSC14291AUH080' RFF+AAAY:3' LOC+11+USBOS' LOC+7+USBOS' MEA+AAE+G+KGM:15740' TMP+2+-18.0:CEL' FTX+AAA+++ICE CREAM'</p>	<p>Reefer temperature -18°C</p>
---	---------------------------------

<p>EQD+CN+*C080E00002+4310:102:5++2+5' RFF+BN:MSC81692012' RFF+AAAY:4' LOC+11+USNYC' LOC+7+USLAX' MEA+AAE+G+KGM:23300' FTX+HAN++UD' FTX+AAA+++ENGINE PARTS' CNT+16:4' UNT+42+046140' UNZ+1+023497'</p>	<p>Transhipment on destination: Los Angeles (USLAX) via New York (USNYC)</p> <p>Stowage info: Under Deck</p>
--	--

APPENDIX A : Importancy of frequent electronical daily move reporting for loading instructions (export containers)

To prevent dummy container numbers:

The use of dummy container numbers can be significantly decreased by reporting the terminal container moves (with CODECO message) more often. If Hesse-Noord Natie reports the gate in moves more frequently, these reported container numbers can be linked to the COPRAR message. An increased daily moves reporting is also important for providing EDI –bookings (COPARN message).

To provide more accurate container specifications in COPRAR:

Also information such as:

ISO code
IMO stickers
over-dimensions
temperature settings
...

Will be provided in the electronical daily moves (gate in) message (CODECO or COMORE). If these messages are send frequently by Hesse-Noord Natie, our customer's database can be updated with last minute accurate container information (which was checked at our gate in). Undoubtedly, this will result in a very "up to date" COPRAR EDI message and a decreased number of errors.

To increase the daily moves reporting frequency, please contact the Hesse-Noord Natie Electronic Business Group.

APPENDIX B : Some extra remarks on the use of free text segments :

Our main goal through the use of EDI is to process customer info automatically. Free text can not be interpreted by computers and therefore the use of free text should have to be kept to a strict minimum. A list of common misuse of the FTX segment is given below, also in addition, the consequences are mentioned.

Do not pass the goods description through use of the FTX+AAI segment. Use the FTX+AAA segment instead.

This normally will go unnoticed by the Hesse-Noord Natie operational department (automated EDI processing).

Do not pass the CSC weight through use of the FTX segment. Use the MEA segment instead, as stated earlier above.

This normally will go unnoticed by our operational department (automated EDI processing).

Although this is a free text segment, some characters can't be used or can't be used without the preceding EDIFACT release character: "?" (according to level A character set). Here follows a list of most occurring "problem" –characters:

“ ‘ ”

In EDIFACT, this character is known as a segment separator. If this character has to be interpreted as free text, it has to be preceded by the release character "?". Otherwise, the text after the "" character will be interpreted as a new segment with an error as result.

Example:

FTX+AAI+++1 x 20' FLAT' should be FTX+AAI:1 x 20?' FLAT'

“ + ”

In EDIFACT, this character is known as a data element separator. If this character has to be interpreted as free text, it has to be preceded by "?". Otherwise, the text after the "+" character will be interpreted as a new data element with an error as result.

Example:

FTX+AAA+++TIRES + ENGINE PARTS' should be FTX+AAA:TIRES ?+ ENGINE PARTS'

“ : ”

In EDIFACT, this character is known as a composite data element separator. If this character has to be interpreted as free text, it has to be preceded by "?". Otherwise, the text after the ":" character will be interpreted as a new composite data element with an error as result.

Example:

FTX+AAA+++FRUITS: APPLES AND PEACHES' should be FTX+AAA:FRUITS?: APPLES AND PEACHES'

“ ? ”

In EDIFACT, this character is known as a release character and should never be used as free text. Sometimes this character is used as a question mark in free text at the end if an

FTX segment. In that case, this “?” character should be preceded by another “?” character. Otherwise the system ignores a following data element –or segment separator with an error as result.

Example:

FTX+AAI+++DANGEROUS CARGO?’ should be FTX+AAI:DANGEROUS CARGO??’

“ °”, “#”

In EDIFACT, these characters are not supported and should never be used.

=> Here follow some special characters that **can** be used in EDIFACT:

. - , () / = ! “ % & * ; < > ◂

See also APPENDIX C for Level A character set details

APPENDIX C: Level A character set in detail (see also “Interchange header – UNB –segment”):

Letters, upper case	A to Z
Numerals	0 to 9
Space character	
Full stop	.
Comma	,
Hyphen/minus sign	-
Opening parentheses	(
Closing parentheses)
Oblique stroke (slash)	/
Equals sign	=

Reserved for use as:

Apostrophe	' segment terminator
Plus sign	+ segment tag and data element separator
Colon	: component data element separator
Question mark	? release character

? immediately preceding one of the characters ' + : ? restores their normal meaning. E.g. 10?+10=20 means 10+10=20. Question mark is represented by ??.

The following characters are part of the level A character set but **cannot** be used internationally in telex transmissions:

Exclamation mark	!
Quotation mark	"
Percentage sign	%
Ampersand	&
Asterisk	*
Semi-colon	;
Less-than sign	<
Greater-than sign	>
Degree sign	°
Cross sign	#